

DATRON M10 Pro

Precise – Ridgid – Accurate
Large-Format Milling up to 40,000 rpm

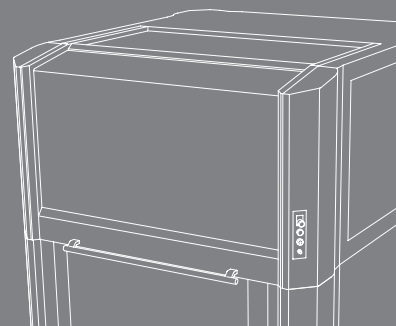

Machine dimensions

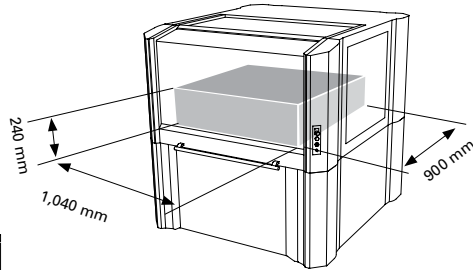
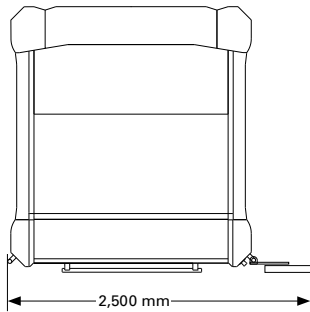
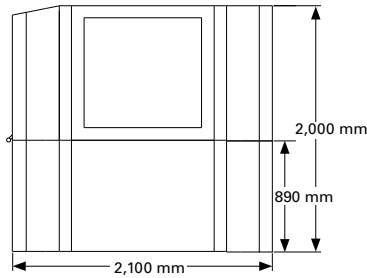
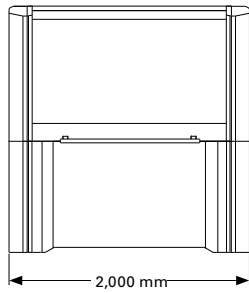

The DATRON M10 Pro is a CNC machine for applications demanding the highest accuracy and productivity.

Standard features on the M10 Pro CNC milling machine:

- Machining table made of solid Granite, with a Steel protective enclosure
- CNC control system for three to six axes
- Microsoft® Windows® controller (computer)
- Network and USB interface for data exchange
- Menu-guided CNC programming software WinCNC



Technical Data	M10 Pro	
Machining table	Solid Granite table with Steel column	
Travels Z stroke = 240 mm	1,040 mm (X) x 900 mm (Y) or, with tool changer 720 mm (Y)	
Portal height	200 mm	
Installation dimensions without operating PC (W x D x H)	2,000 mm x 2,100 mm x 2,000 mm	
Conical workholding fixtures integrated into table	✓	
Integrated zero-point clamping system	(optional)	
Fast digital servo control with Microsoft® Windows® control computer	✓	
Easy-to-use hand-held control unit	✓	
Drive system: Digital servo drives; Linear guideways	✓	
Linear scales	-	✓
Coolant system	✓	
Machining spindle	Precision-Power S Syncro 3.0 kW HF spindle, up to 40,000 rpm	
Tool changer with integrated tool length sensor	11 tools with HSK-E 25 tool holding fixture (optional for 22 tools)	
Feed rates	up to 30 m/min	
Positioning feed (rapids)	up to 30 m/min	
Weight	approx. 1.8 t	
Article Number	0A01013A*/B	0A01014A*/B

The information in this brochure includes current descriptions or performance features which are subject to change due to further development of the products. The descriptions and performance features are binding only if they are expressly agreed in writing at the time of conclusion of the contract.

CNC_M10_Pro_US_V50

* machining table with cut-out at front